

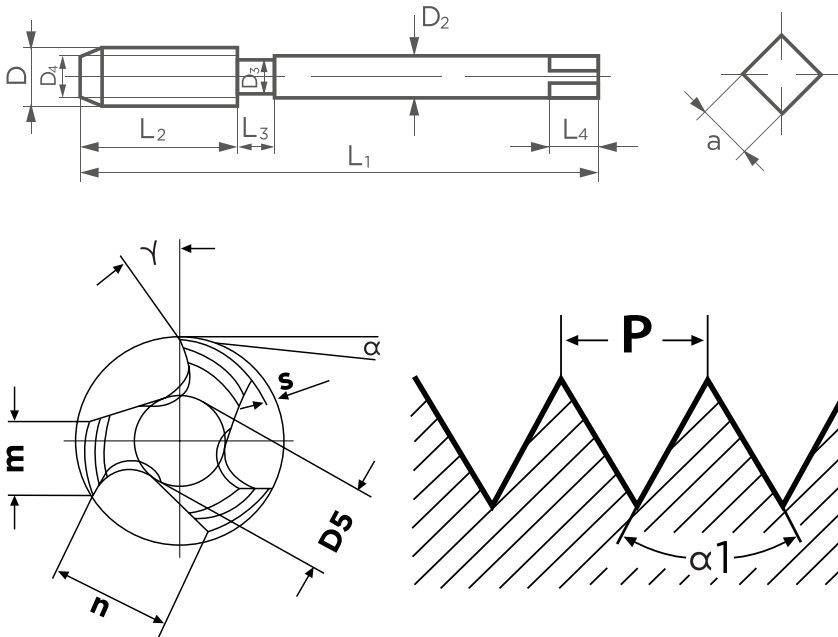

TECHNICAL INFORMATION



D	Nominal diameter
D ₂	Shank diameter
D ₃	Neck diameter
D ₄	Point diameter
D ₅	Minor diameter
L ₁	Overall length
L ₂	Thread length
L ₃	Neck length
L ₄	Square length
P	Pitch
a	Square
m	Land width
n	Flute width
s	Thread relief
α	Relief angle
γ	Rake angle
α ₁	Thread angle

Leads of Hand Taps, Sets of 3 pcs.

approx. 6 threads

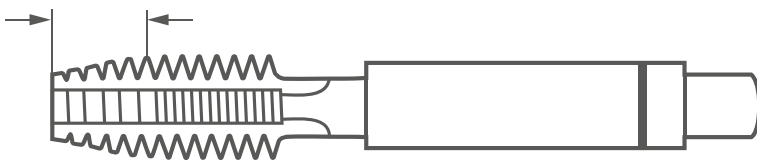

Nr. 1
Rougher, 6-8 Threads Lead

approx. 4 threads

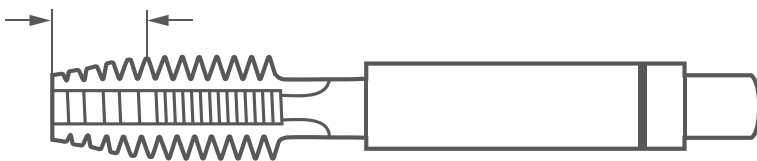

Nr. 2
Intermediate, 4-5 Threads Lead

approx. 2 threads

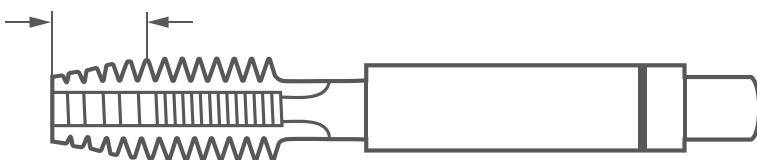

Nr. 3
Finisher, 2-3 Threads Lead

Leads of Hand Taps, Sets of 2 pcs.

approx. 5 threads

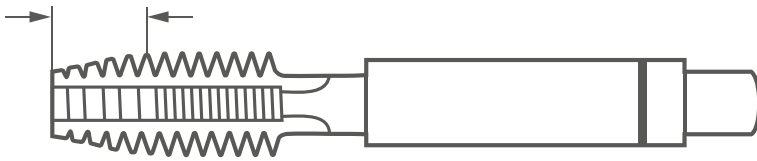

Nr. 1
Rougher, 5-6 Threads Lead

approx. 2 threads

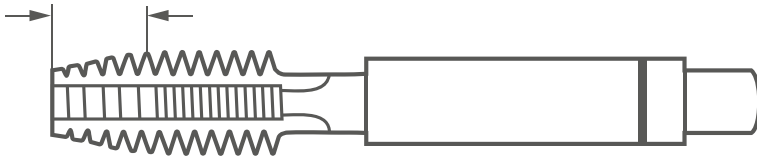

Nr. 2
Finisher, 2-3 Threads Lead

SNITTAPPE
ALT I GEVINDVÆRKTØJER

